

AMANI

UK

CY

ES

PT

LV

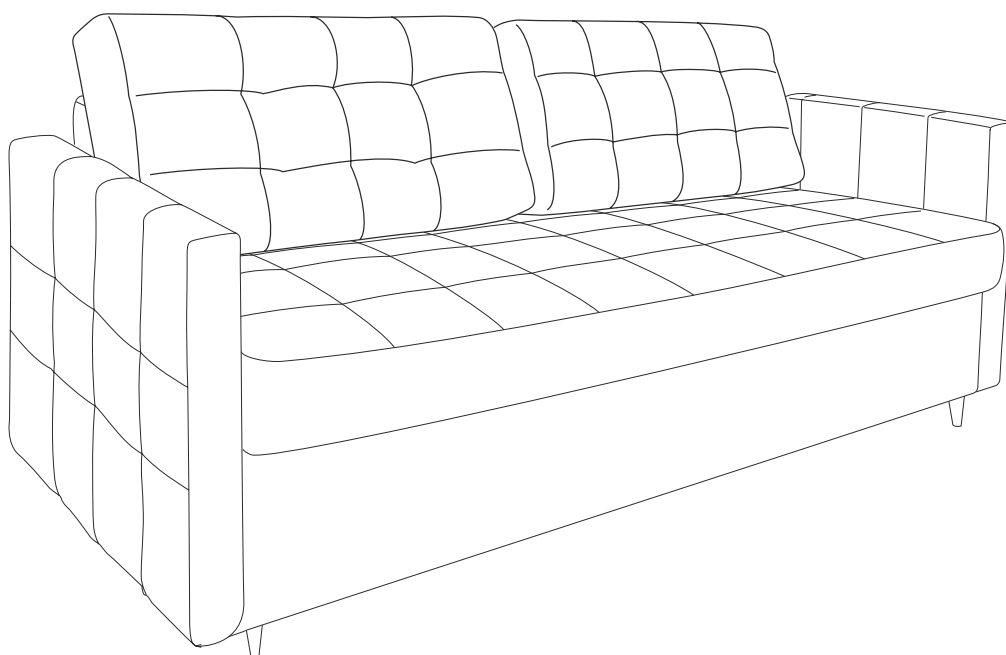

Sleep.8

AMANI

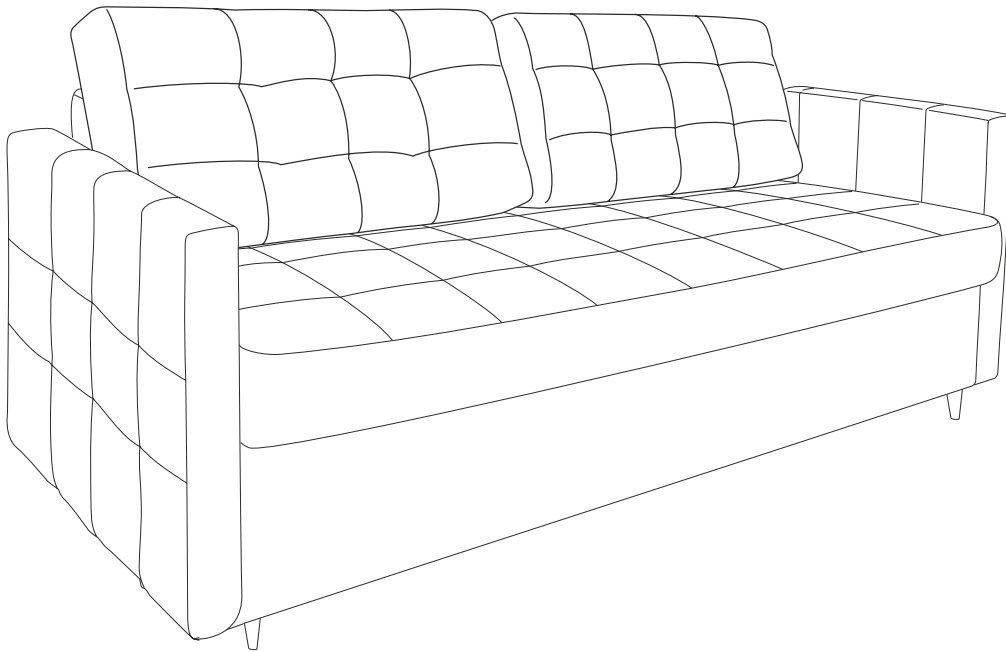









Before assembly:

1. Check all the component parts for any breakage and visible defects. Complaints about any damage to them will only be processed if there are NO signs of attempts at assembly on them.
2. Keep the packaging until assembly is complete. If, during assembly, parts are found to be missing or damaged, make sure to keep the packaging until a company representative is dispatched to your location.
3. Ensure that the number of parts and fittings corresponds to that on the list of components and subdivide the fittings accordingly. The manufacturing company reserves the right to make structural changes to the product, and replace fittings and metal components with analogues that do not have a negative impact on the item's appearance and its function.
4. Follow the assembly instructions in this document. If the assembly and product use instructions are not followed, the manufacturing company will no longer meet any warranty commitments it has made. Please keep the assembly and product use instructions the entire time the product remains in use.
5. Move all the component parts carefully and avoid yanking them. Place them securely so that they do not fall or hit anything. Assemble the product on an even surface.

Tools required for assembly:

Star screwdriver	
-------------------------	---

Package	Component part	Quantity	Figure
No 1	<i>Linen storage unit</i>	1	
	<i>Seat</i>	1	
	<i>Back cushions</i>	2	
	<i>Supports</i>	6	
	<i>Silicone lubricant</i>	1	
	<i>Package with fittings</i>		
	<i>Assembly instructions</i>	1	
	<i>Product use instructions</i>	1	
No 2	<i>Adjustable backrest</i>	1	
	<i>Back support</i>	1	
No 3	<i>Armrests</i>	2	
Package with fittings	<i>Bolt M6x25</i>	2	 V1
	<i>Bolt M6x65</i>	4	 V2

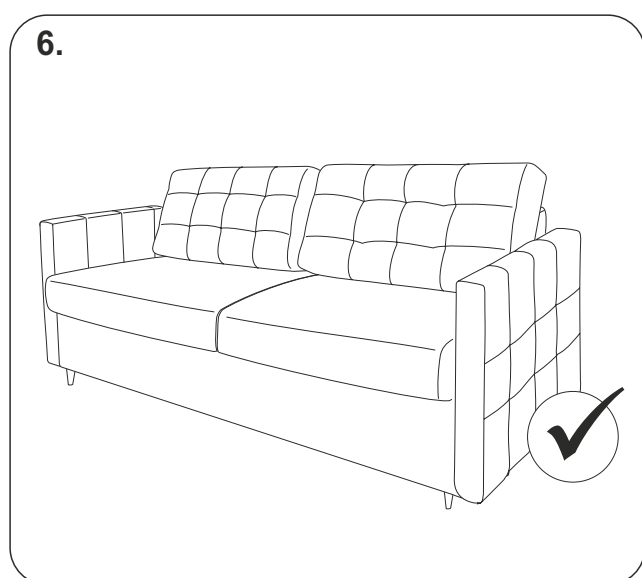
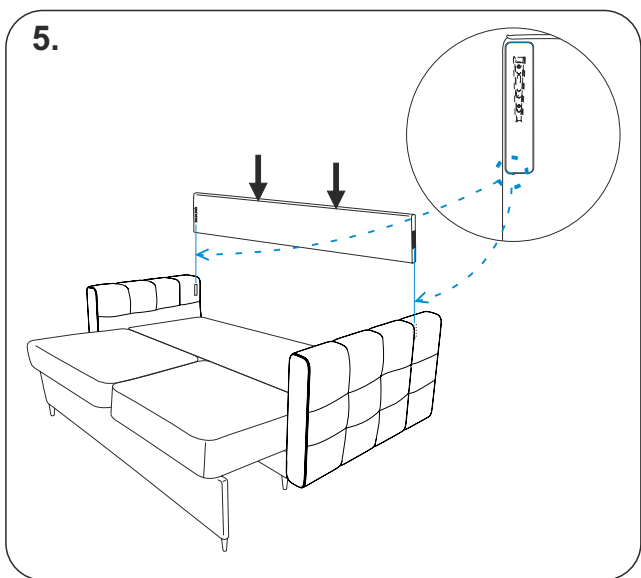
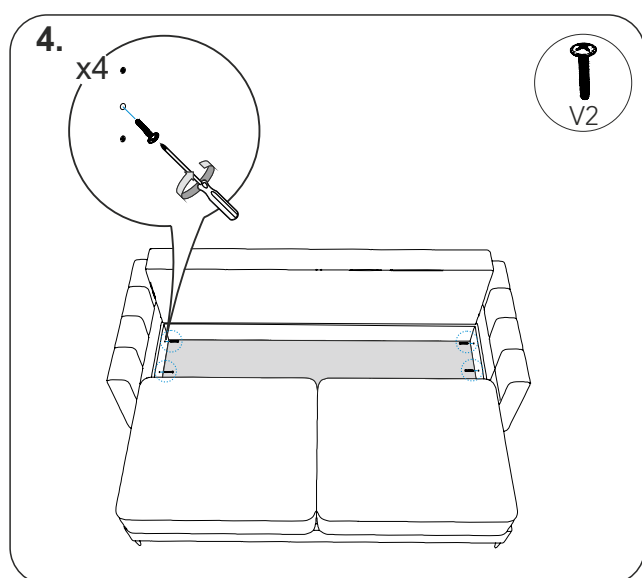
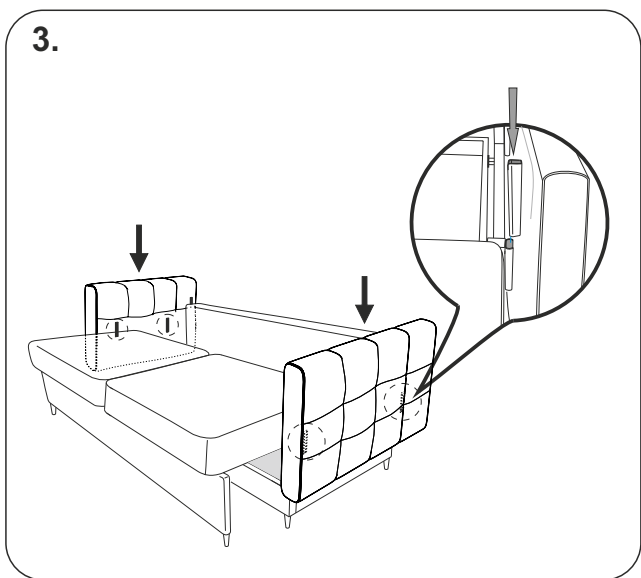
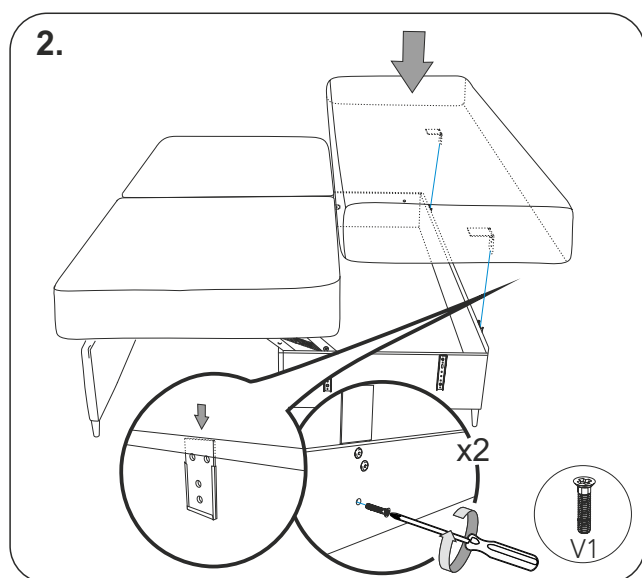
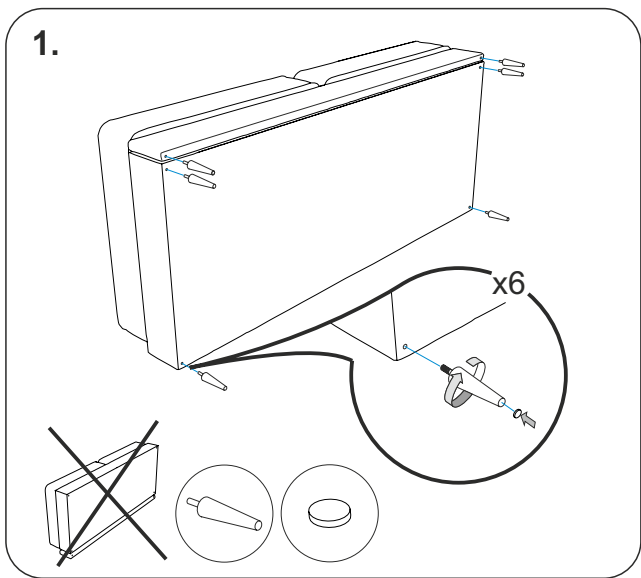

! The company recommends periodically (once every 6 months) lubricating the hinge assembly mechanism of the convertible sofa bed with the silicone lubricant

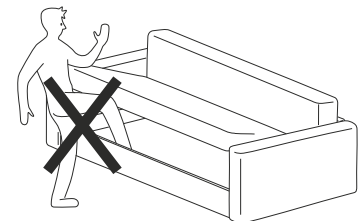
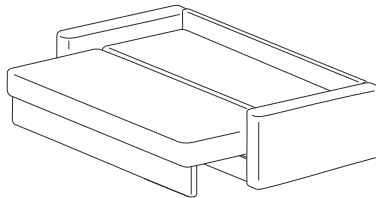
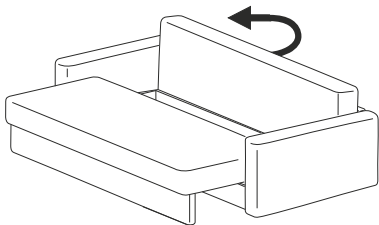
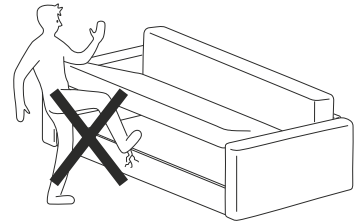
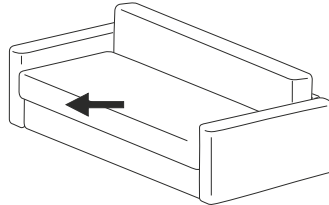
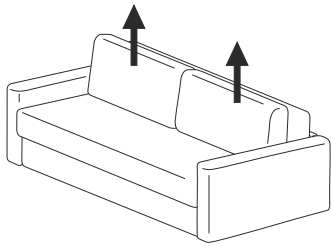
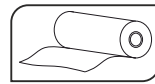
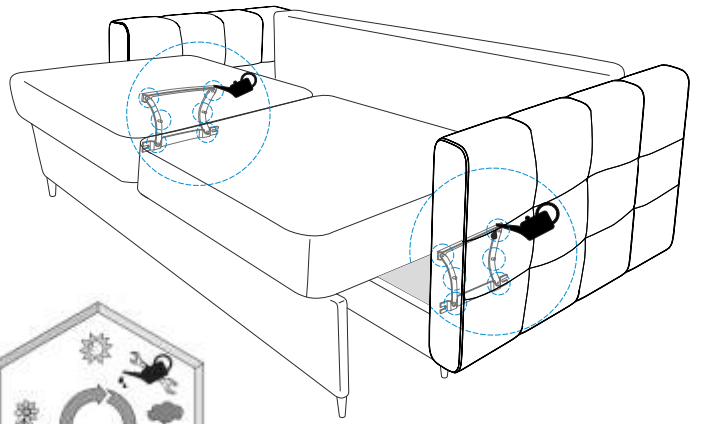
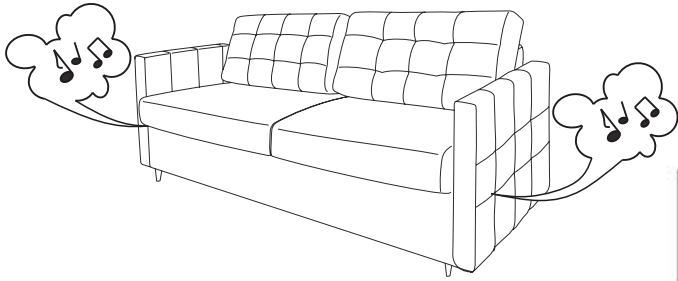

AMANI

CY

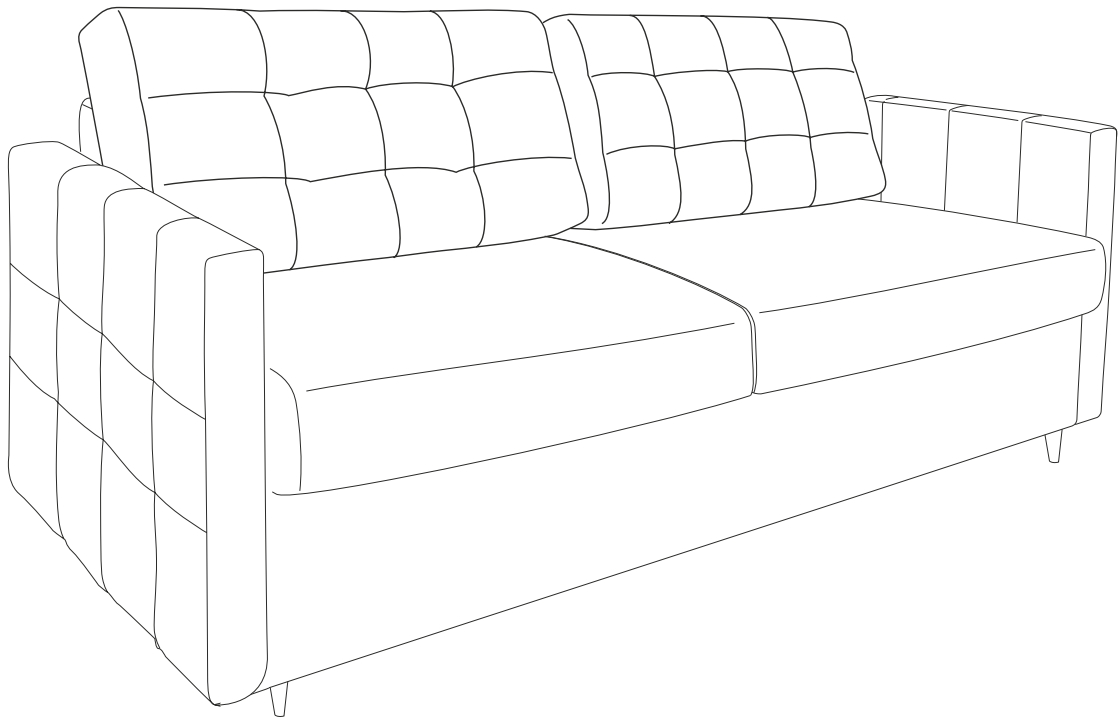

Sleep.8

Πριν τη συναρμολόγηση:

1.Ελέγξτε την εμφάνιση και την ακεραιότητα των εξαρτημάτων στη συσκευασία. Οι απαιτήσεις ζημίας αποδέχονται μόνο για προϊόντα ΧΩΡΙΣ ίχνη συναρμολόγησης.

2.Αποθηκεύστε τη συσκευασία μέχρι το τέλος της συναρμολόγησης! Εάν κατά τη διαδικασία συναρμολόγησης εντοπιστεί ελαττωματικό και ελλιπές προϊόν, πρέπει να αποθηκεύσετε τη συσκευασία μέχρι να φύγει ένας εκπρόσωπος της εμπορικής εταιρείας.









3.Ελέγξτε τον αριθμό των εξαρτημάτων σύμφωνα με τη λίστα συλλογής, αποσυναρμολογήστε τα εξαρτήματα σε ομάδες. Ο κατασκευαστής διατηρεί το δικαίωμα να κάνει αλλαγές στο σχεδιασμό του προϊόντος, να αντικαταστήσει εξαρτήματα και εξοπλισμό με παρόμοια που δεν επιδεινώνουν την εμφάνιση και δεν επηρεάζουν τις λειτουργικές ιδιότητες του προϊόντος.

4.Ακολουθήστε τη σειρά συναρμολόγησης που παρέχεται σε αυτό το εγχειρίδιο! Η μη τήρηση των οδηγιών συναρμολόγησης και λειτουργίας ακυρώνει την εγγύηση του κατασκευαστή. Το εγχειρίδιο συναρμολόγησης και λειτουργίας πρέπει να διατηρούνται για όλη την περίοδο λειτουργίας του προϊόντος.

5.Μετακινήστε προσεκτικά όλα τα εξαρτήματα, χωρίς να χτυπήσετε, τοποθετήστε τα με ασφάλεια, αποφύγετε την πτώση και την πρόσκρουση! Συναρμολογήστε το προϊόν σε επίπεδη επιφάνεια.

Για τη συναρμολόγηση χρειάζεστε:

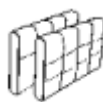
Σταυροκατσάβιδο	
-----------------	---

Συσκευασία	Εξάρτημα	Αριθμός	Εικόνα
No 1	Κουτί για ρούχα	1	
	Κάθισμα	1	
	Πίσω μαξιλάρια	2	
	Υποστηρίξεις	6	
	Γράσο σιλικόνης	1	
	Συσκευασία με εξαρτήματα		
	Οδηγία συναρμολόγησης	1	
	Διαβατήριο υπηρεσίας	1	
No 2	Ανακλινόμενη πλάτη	1	
	Πλάτη του καθίσματος	1	
No 3	Υποβραχιόνια	2	
Συσκευασία με εξαρτήματα	Βίδα M6 x 25	2	 V1
	Βίδα M6 x 65	4	 V2

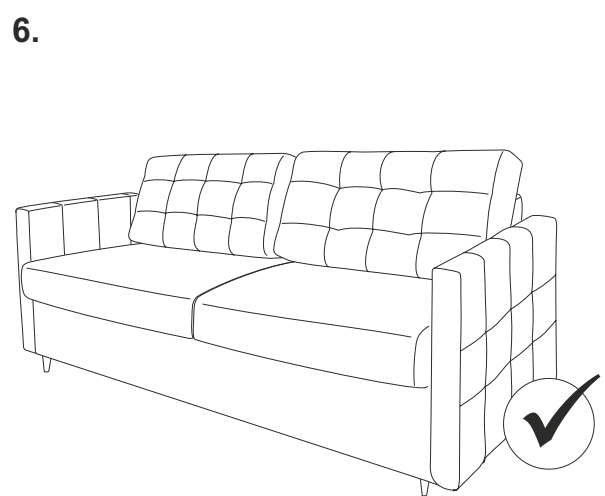
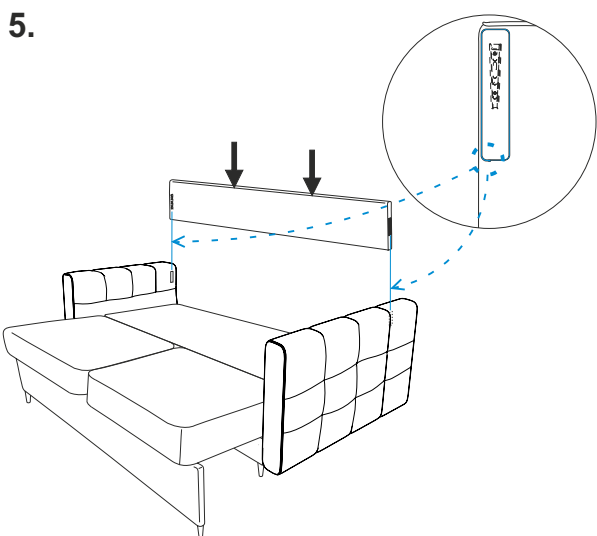
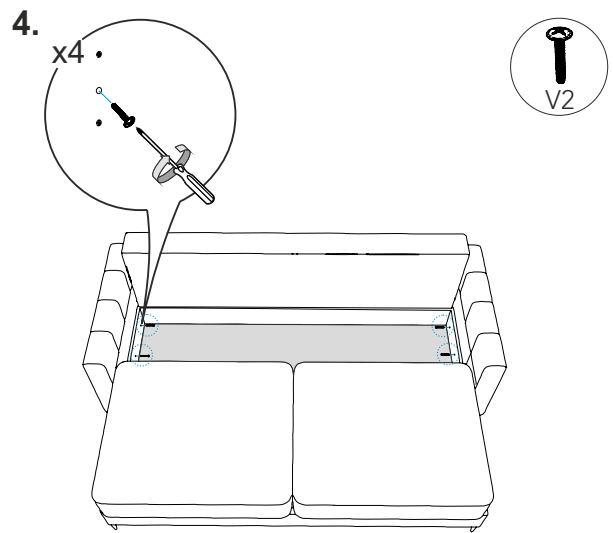
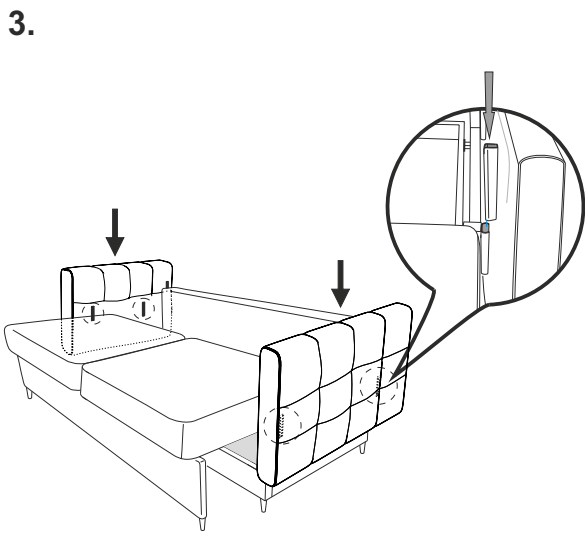
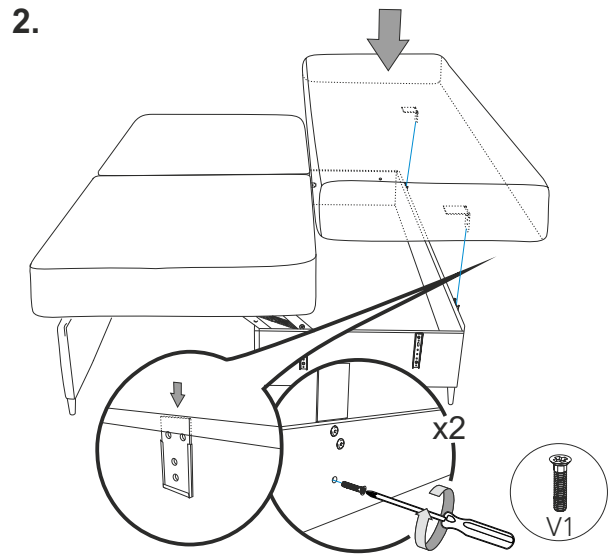
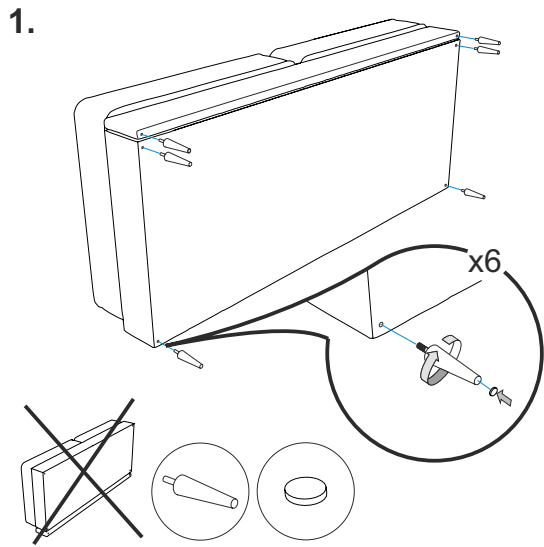

Συνιστάται περιοδικά (μία φορά κάθε έξι μήνες) να λιπαίνετε τα μέρη του μηχανισμού μετατροπής του καναπέ με γράσο σιλικόνης.

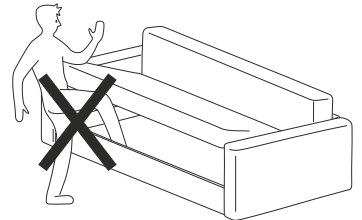
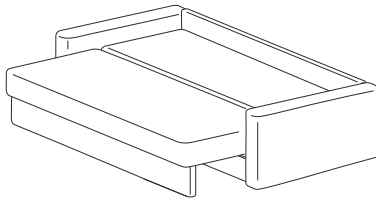
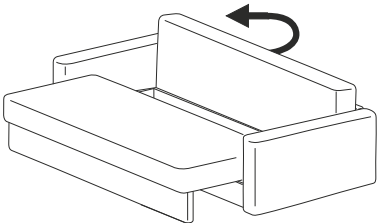
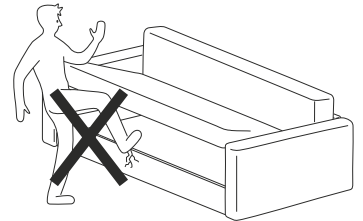
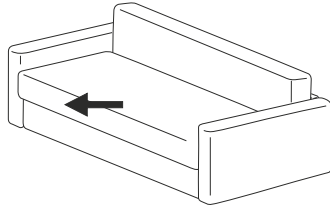
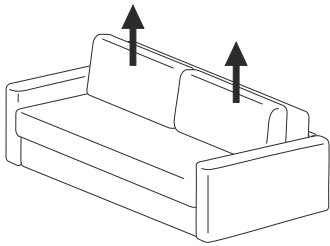
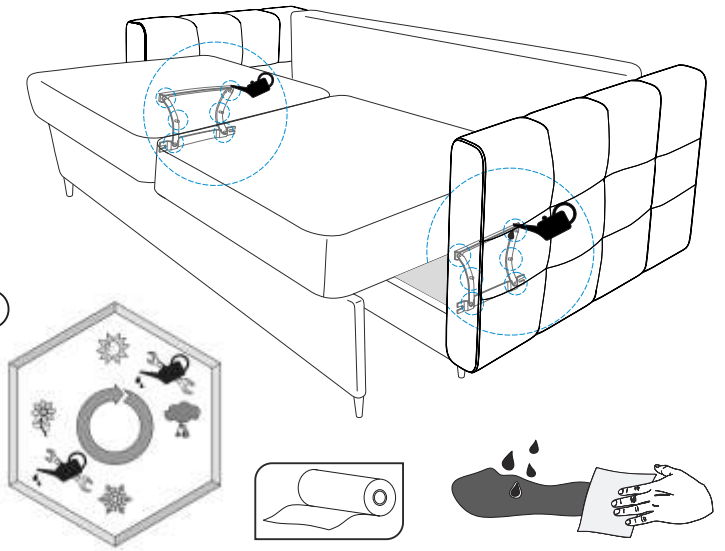
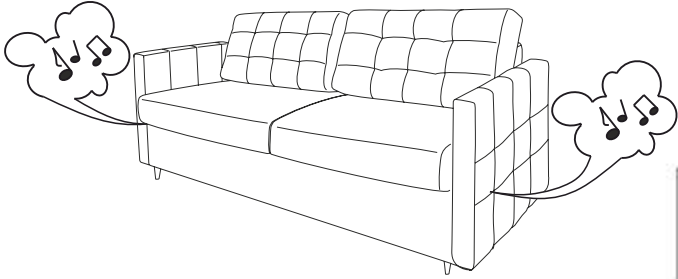

AMANI

ES

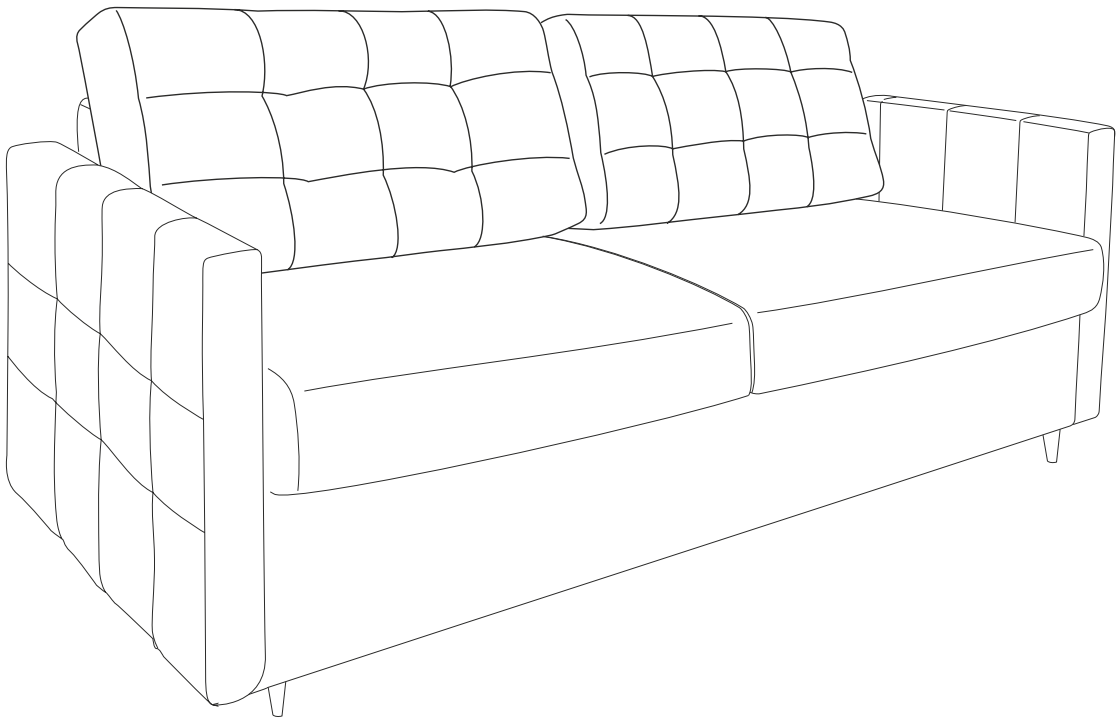

Sleep.8

Antes del montaje:

1. ¡Comprueben el aspecto exterior y la integridad de las piezas empaquetadas! Sólo se aceptan reclamaciones por daños en productos SIN marcas de montaje.

2. ¡Guarden el embalaje hasta que haya terminado el montaje! Si durante el montaje se detecta algún defecto o falta de integridad del producto, guarden el embalaje hasta que el representante de la empresa venga a visitarles.









3. Comprueben la cantidad de piezas y herrajes según la lista de componentes y dividan los herrajes en grupos. La empresa fabricante se reserva el derecho a realizar cambios de diseño del producto, así como sustituir los herrajes y accesorios por otros similares que no hagan peor el aspecto exterior y no afecten a las propiedades funcionales del producto.

4. ¡Sigán las reglas de montaje especificadas en este Manual! Si las reglas de montaje y explotación cumplan indebidamente, la empresa fabricante se libera de las obligaciones relacionadas con garantía. Los Manuales de montaje y explotación deben guardarse durante toda la vida útil del producto.

5. Trasláden con cuidado y suavemente todas las piezas, colóquenlas en una posición estable, eviten que se caigan y se choquen. ¡El montaje del sofá debe hacerse solamente en una superficie plana!

Para montar el sofá este es necesario:

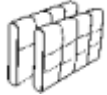
Destornillador de estrella	
-----------------------------------	---

Embalaje	Pieza	Cantidad	Imagen
No 1	Cajón de ropa	1	
	Asiento	1	
	Almohadas de espalda	2	
	Soportes	6	
	Lubricante de silicona	1	
	Paquete con herrajes		
	Manual de montaje	1	
	Manual de explotación	1	
No 2	Respaldo plegable	1	
	Respaldo trasero	1	
No 3	Reposabrazos	2	
Paquete con herrajes	Tornillo M6 x 25	2	 V1
	Tornillo M6 x 65	4	 V2

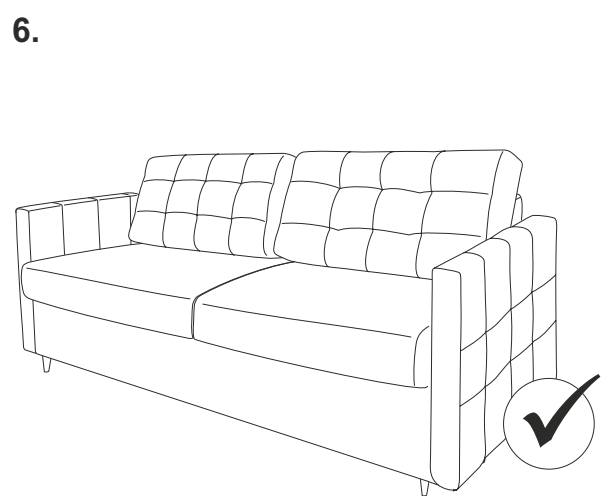
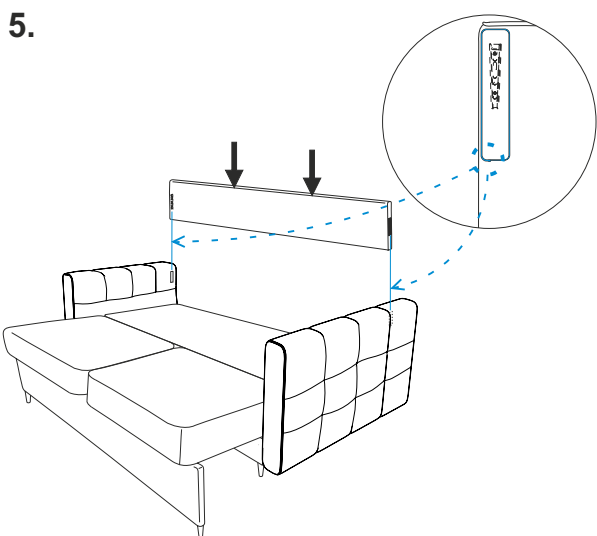
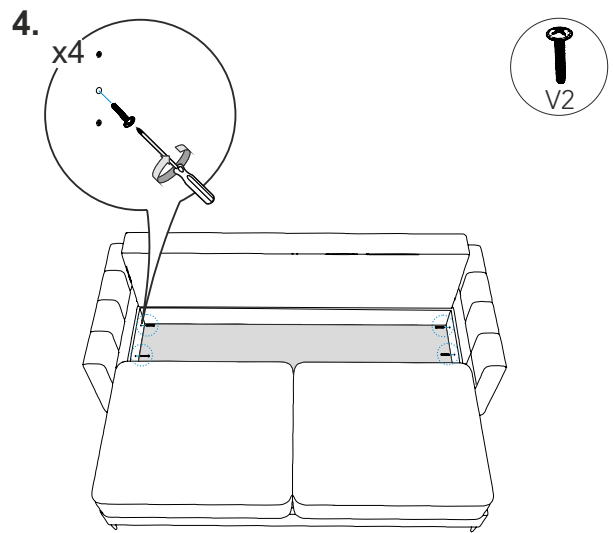
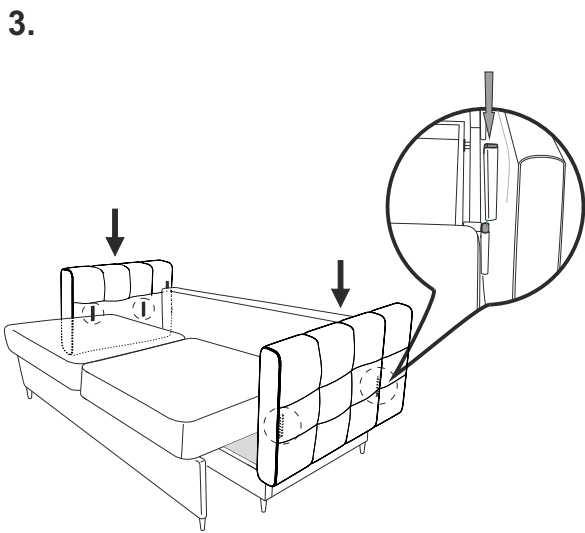
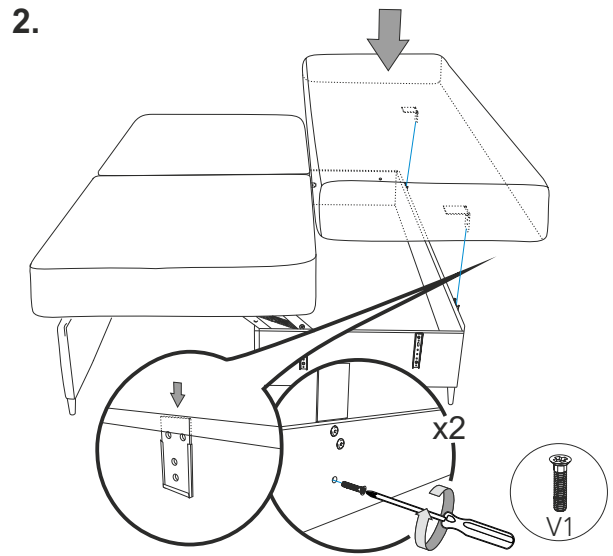
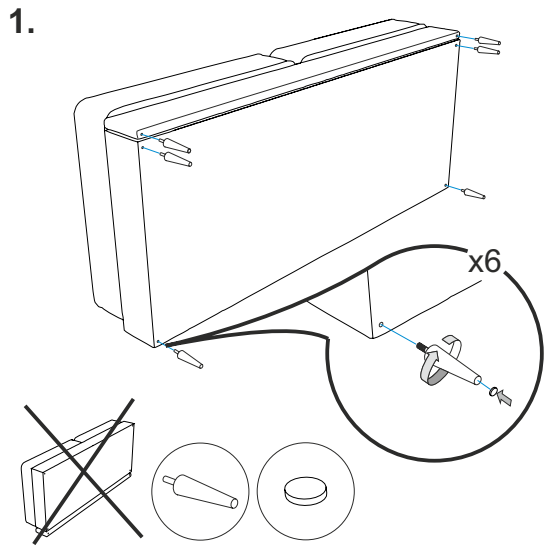

! Se recomienda periódicamente (al menos una vez cada seis meses)
lubricar conexiones resbaladizas articuladas del mecanismo
de transformación del sofá.

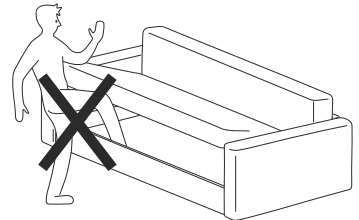
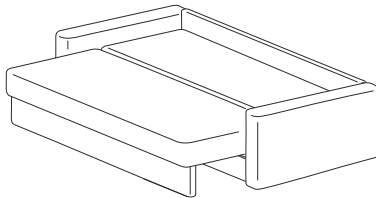
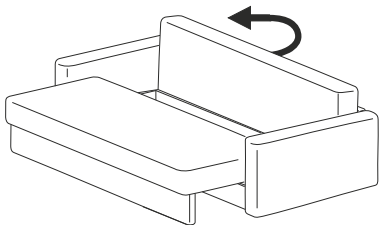
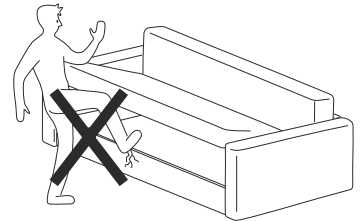
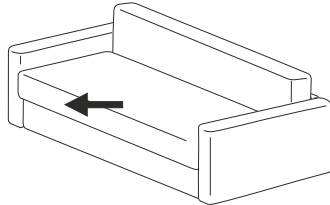
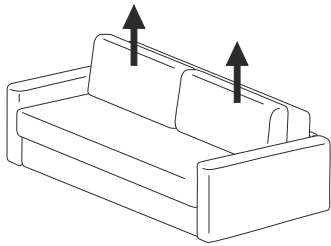
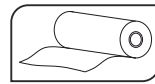
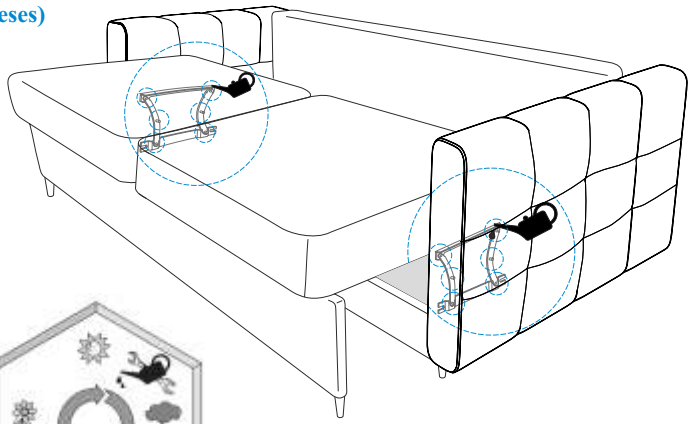
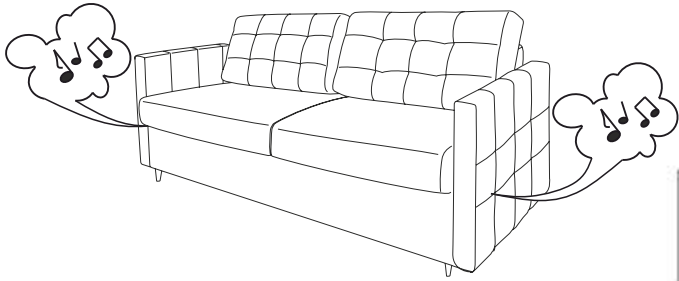

AMANI

PT

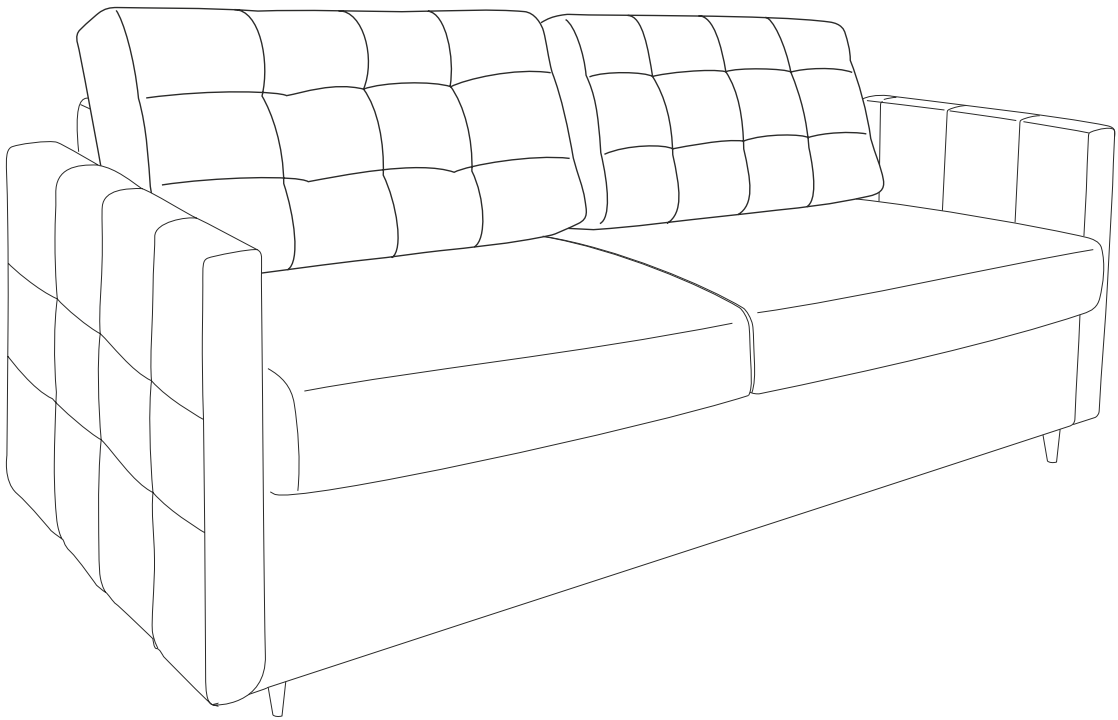









Sleep.8

Antes da montagem:

1. Verifique a aparência e integridade das peças da embalagem. As reclamações pelos seus danos são aceites apenas para produtos SEM vestígios de montagem.
2. Guarde a embalagem até ao final da montagem! Caso seja detetado um defeito ou faltem peças do produto durante o processo de montagem, é necessário guardar a embalagem até à visita de um representante da empresa comercial.
3. Verifique o número de peças e acessórios de acordo com a lista, separe os acessórios por grupos. O fabricante reserva-se ao direito de fazer alterações no projeto do produto, substituir acessórios e ferragens por outros semelhantes, que não afetarem a aparência e as propriedades funcionais do produto.
4. Siga a ordem de montagem apresentada neste manual! Em caso de incumprimento das instruções de montagem e operação, fabricante cancela a garantia do produto. As instruções de montagem e de operação devem ser mantidas durante todo o período de funcionamento do produto.
5. Mova todas as peças com cuidado, sem sacudir, coloque-as firmemente, evite quedas e pancadas! A montagem do produto é realizada numa superfície plana.

Para a montagem é necessário:

Chave de fendas de ponta Philips	
---	---

Embalage	Peça	Quantidade	Imagem
No 1	Caixa de linho	1	
	Assento	1	
	Almofadas de espalda	2	
	Almofadas posteriores	6	
	Lubrificante de silicone	1	
	Pacote com ferragens		
	Instruções de montagem	1	
	Certificado de serviço	1	
No 2	Encosto reclinável	1	
	Encosto traseiro	1	
No 3	Apoios de braço	2	
Pacote com ferragens	Parafusos M6 x 25	2	 V1
	Parafusos M6 x 65	4	 V2

! **Recomenda-se lubrificar periodicamente (1 vez a cada seis meses) as articulações do mecanismo de transformação do sofá com lubrificante de silicone.**

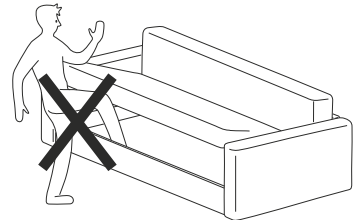
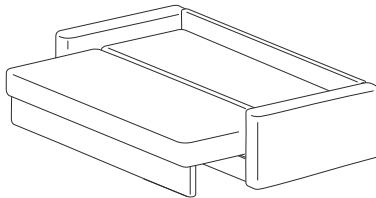
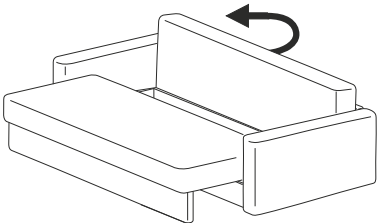
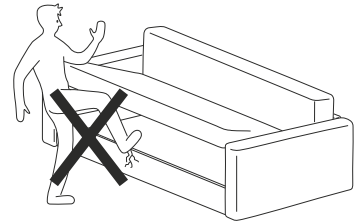
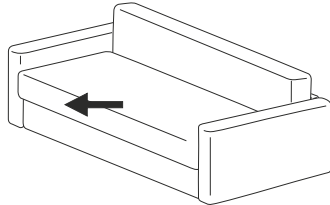
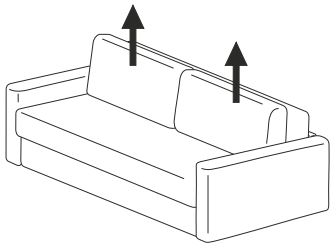
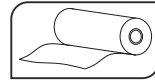
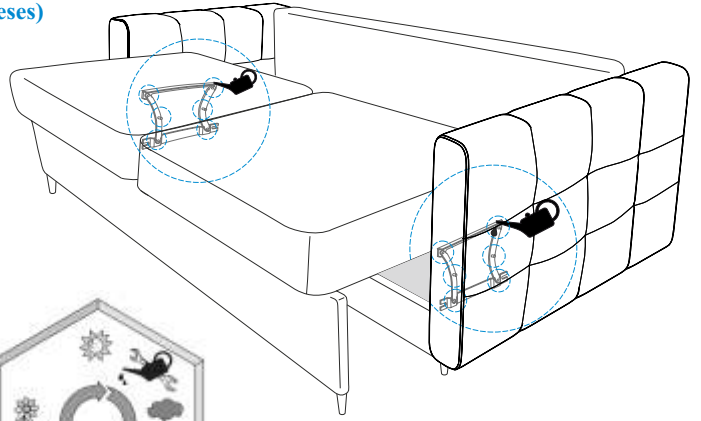
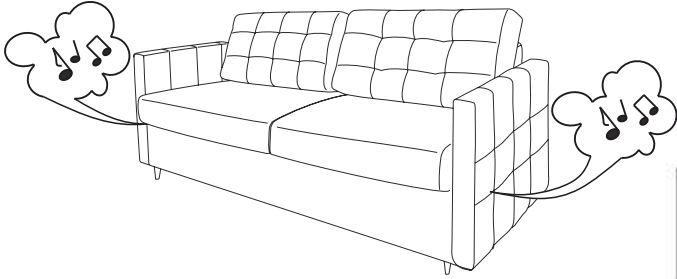

AMANI

LV

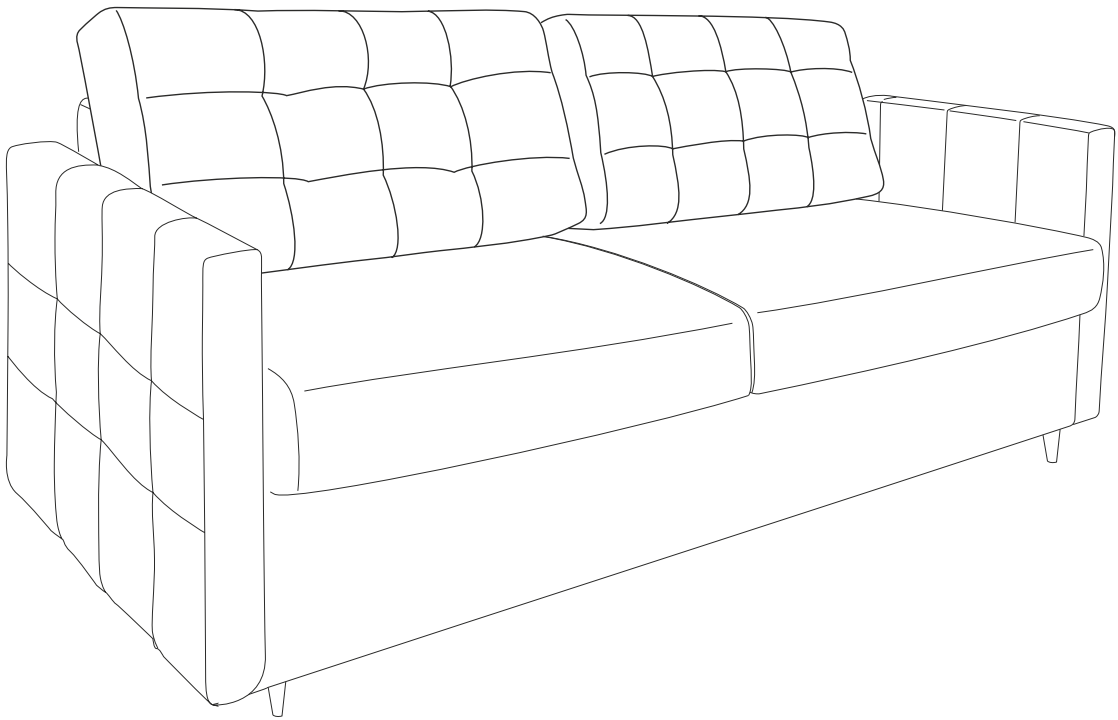









Sleep.8

Pirms montāžas darbiem:

1. Pārbaudiet detaļu iepakojuma izskatu un pilnību. Prasības par to bojājumiem tiek pieņemtas tikai par izstrādājumiem BEZ montāžas pēdām.
2. Saglabājiet iepakojumu līdz montāžas beigām! Ja montāžas procesā tiek atklāts produkta defekts un nepilnība, jums ir jā saglabā iesaiņojums, līdz tirdzniecības uzņēmuma pārstāvis atbrauks pie Jums.
3. Pārbaudiet detaļu un furnitūras skaitu atbilstoši pasūtījuma komplektācijas sarakstam, sadaliet piederumus grupās Ražotājs patur tiesības veikt izstrādājuma konstruktīvās izmaiņas, nomainīt furnitūru un stiprinājumus ar analogiem, kas nepasliktina izskatu un neietekmē produkta funkcionālās īpašības.
4. Izpildiet šajā instrukcijā norādīto montāžas kārtību! Montāžas un lietošanas instrukcijas neievērošana anulē ražotāja garantijas atbildību. Montāžas un lietošanas instrukcijas jā saglabā visu izstrādājuma kalpošanas laiku.
5. Pārvietojiet visas detaļas uzmanīgi, bez raustīšanās, novietojiet tās stabilā veidā, izvairieties no kritieniem un triecieniem! Veiciet izstrādājuma montāžas darbus uz līdzenas virsmas.

Montāžas darbiem ir nepieciešams:

Skrūvgriezis krusta	
----------------------------	---

Embalage	Peça	Quantidade	Imagem
No 1	Caixa de linho	1	
	Assento	1	
	Almohadas de espalda	2	
	Almofadas posteriores	6	
	Lubrificante de silicone	1	
	Pacote com ferragens		
	Instruções de montagem	1	
	Certificado de serviço	1	
No 2	Encosto reclinável	1	
	Encosto traseiro	1	
No 3	Apoios de braço	2	
Pacote com ferragens	Parafusos M6 x 25	2	 V1
	Parafusos M6 x 65	4	 V2

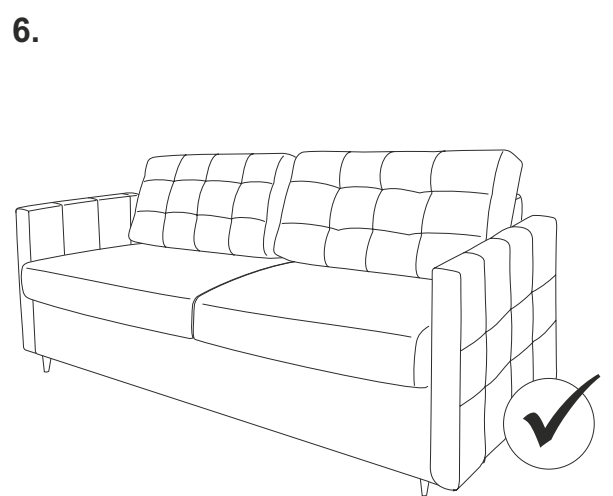
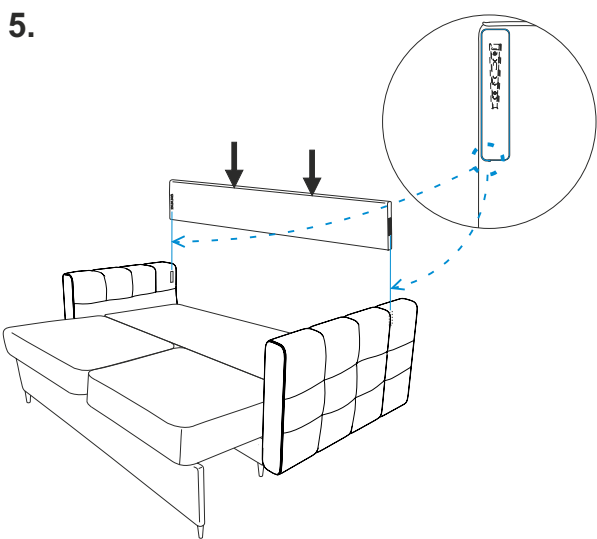
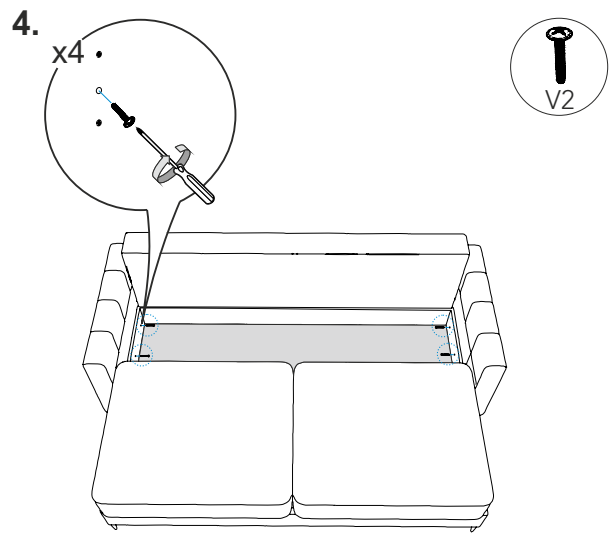
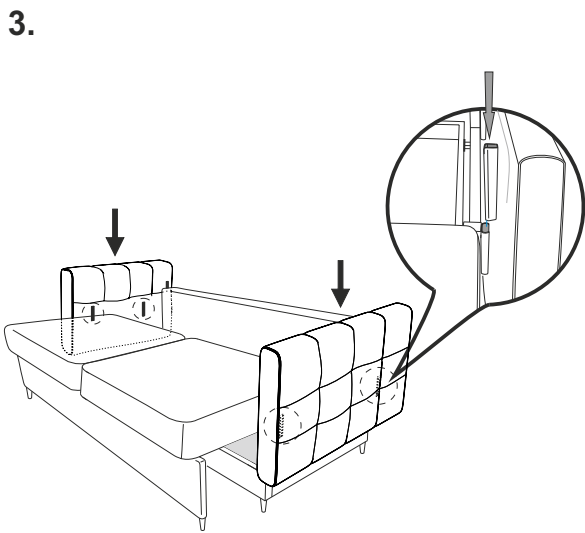
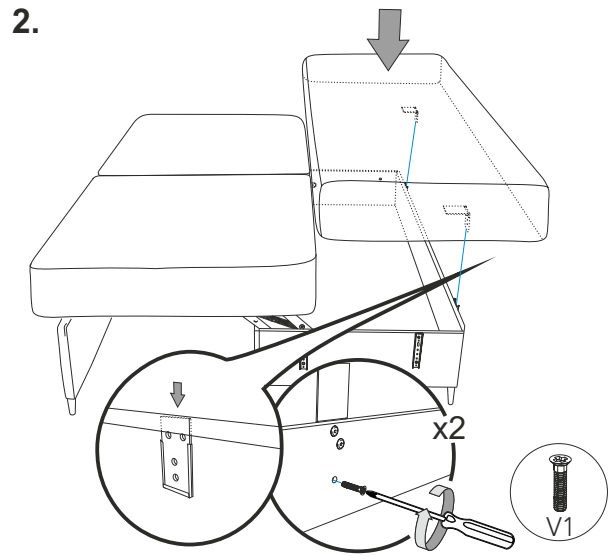
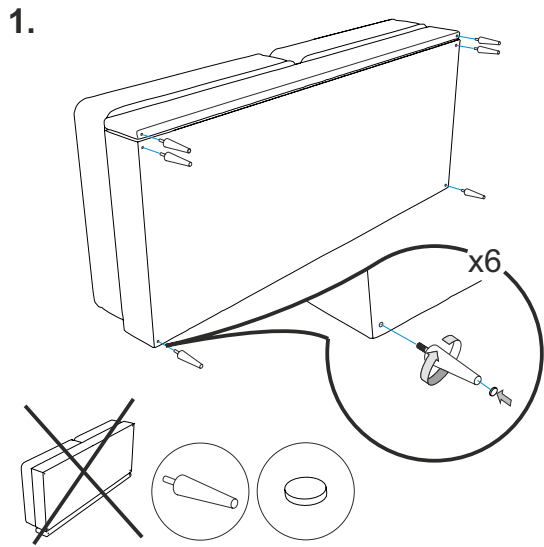

! Ieteicams periodiski (reizi sešos mēnešos) ieeļļot ar silikona smērvielu dīvāna transformācijas mehānisma kustīgā šarnīrbalsta savienojuma vietas

